

Powers™ Controls

TH 188 Unit Mounted Thermostat

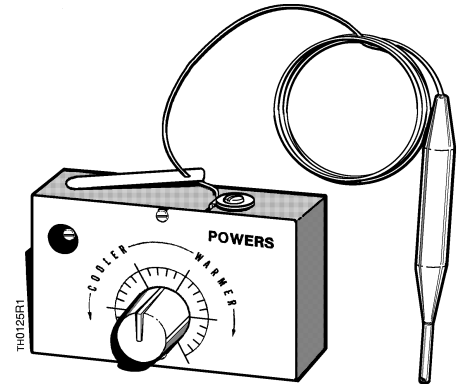

Description

The TH 188 Unit Mounted Thermostat is a remote bulb, gradual acting pneumatic instrument which maintains a pre-selected temperature by positioning pneumatic devices that control a heating or cooling medium.

Replacement thermostats are available for Honeywell models LP916Bxxxx and Johnson Controls model T-3300-2.

Features

- Liquid filled sensing element
- Direct acting (DA), reverse acting (RA), and heating-cooling models (HC)
- Mounting bracket provided

Application

The TH 188 thermostat is mounted in fan coil units and unit ventilators to control a space temperature in applications where a wall thermostat cannot be used.

In unit ventilator applications, where the unit mounted thermostat pilots a Limitem, use a thermostat having a 40 scim (11ml/s) restrictor. The Limitem has a built-in bleed to prevent control air from being trapped.

To assure good control, the remote bulb sensing element must be located so that space air passes over it continuously.

Product Numbers

Table 1.

Thermostat Action and Model Number	Product Number	
	With 20 Scim (5.5 ml/s) Restrictor	With 40 Scim (11 ml/s) Restrictor
HC (DA & RA) TH 188 HC	---	188-0030
DA TH 188D	---	188-0031
RA TH 188R	188-0024	*
Honeywell HC LP916Bxxxx	---	188-0033
Johnson HC T-3300-2	---	188-0034

*Use 188-0024, but change restrictor.

Specifications	Control action	Heating (DA) and Cooling (RA)
Operating	Direct acting only	
	Reverse acting only	
	Operating range	60° to 85° F (16° to 29° C)
	Operating pressure	30 psi (207 kPa) max.
	Sensitivity range	1 to 5.25 psi per degree F
	(12 to 65 kPa per degree C)	
	Factory sensitivity setting	2.25 psi per degree F
	(28 kPa per degree C)	
	Temperature response	0.2° F (0.1° C)
	Maximum ambient temperature	
	Case	135°F (57°C)
	Bulb	231°F (111°C)
	Scale graduations	1°F (0.55°C)
	Normal air supply pressure	See <i>Table 2</i>
	Air usage	
	*HC, 40 scim restrictor	45 scim (12 ml/s)
	DA, 40 scim restrictor	40 scim (11 ml/s)
	RA, 20 scim restrictor	25 scim (7 ml/s)
	Air capacity	
	*HC, 40 scim rest.	35 scim (9.5 ml/s)
	*HC, 40 scim rest. cooling	120 scim (33 ml/s)
	DA, 40 scim restrictor	35 scim (9.5 ml/s)
	RA, 20 scim restrictor	120 scim (33 ml/s)
	Thermal system	Remote bulb, liquid filled
	*HC air usage and air capacity is the same for Powers, Honeywell, and Johnson.	
Physical	Weight	3 lbs. (1.36 kg)
	Dimensions	See <i>Figure 9</i>
	Air connections	Barbed fitting for 1/4-inch (6.4 mm) OD plastic tubing
	Finish	Corrosion resistant zinc chromate

Table 2. Air Supply Pressure and Changeover.

Type & Model No.	Heating (DA)	Cooling (RA)	Changeover
Powers HC TH 188 HC	25 Psi (172 kPa)	18 psi (124 kPa)	21 psi (145 kPa)
Powers DA TH 188D	25 psi (172 kPa)	--	--
Powers RA TH 188R	--	25 psi (172 kPa)	--
Honeywell HC Lp916Bxxxx	18 psi (124 kPa)	13 psi (90 kPa)	15 psi (103 kPa)
Johnson HC T-3300-2	20 psi (138 kPa)	15 psi (103 kPa)	17 psi (117 kPa)

Accessories	Extension shaft	188-101
	Remote bulb mounting kit	808-517
	Limit stop kit (25 sets/kit)	188-144
	Restrictor replacement kit five 20 scim (5.5 ml/s) and five 40 scim (11 ml/s)	188-159
	Thermostat mounting bracket	188-077

Operation
 (See Figure 1). **NOTE:** Pressures used refer to thermostats calibrated to Powers pressures. See *Table 2* for Honeywell and Johnson Controls supply pressures.

Heating, Direct Acting, 25 psi (172 kPa) Supply
 When the remote bulb senses a falling temperature, the liquid within the thermal system contracts. This allows the pre-load spring to lift the sensitivity arm and throttling pin, which is in contact with the arm. The throttling pin lifts off the nozzle seat reducing the pressure behind the nozzle. This is the direct acting signal of the thermostat. The reduced pressure passes through the return line to a Normally Open (NO) valve. This allows more of the heating medium to flow through the heating coil increasing the heat supplied to the space.

When there is a rise in temperature sensed by the remote bulb, the liquid within the thermal system expands. This expansion moves the sensitivity arm and throttling pin downward, increasing the load on the throttling pin and moving it closer to the seat in the nozzle. Pressure builds up in the chamber below the nozzle until the force of the increased air pressure against the bottom of the throttling pin exactly balances the downward force of the sensitivity arm. This increased pressure reduces the flow of heating medium through the heating coil by closing the normally open valve and reducing the heat supplied to the space.

Cooling, Reverse Acting, 18 psi (124 kPa) Supply
 With an 18 psi (124 kPa) supply pressure, the channel connecting the direct acting signal to the return line port is closed, and the channel connecting the reverse acting signal to that same return line port is opened.

When the remote bulb senses a falling temperature, the liquid within the thermal system contracts, allowing the spring pressure to move the sensitivity arm away from the throttling pin. This allows the built-up pressure to bleed off, lowering the pressure on the reverse acting stage of the thermostat. Thus, the spring pressure opens the supply valve and closes the exhaust valve, increasing the pressure in the return line.

Heating-Cooling Changeover
 With an 18 psi (124 kPa) air supply, the switch spring exerts enough force to overcome the 18 psi (124 kPa) air pressure acting on the switch diaphragm. The ball valve is therefore kept closed, allowing no air to reach the changeover diaphragm. An air pressure increase to 25 psi (172 kPa) will exert enough force on the switching diaphragm to overcome the force of the switch spring and cause the switch diaphragm to move upward. This unseats the switch ball valve and allows full supply pressure to act on the changeover diaphragm. The air pressure force on top of the changeover diaphragm moves the diaphragm down to compress the changeover rod spring. Attached to the changeover rod and changeover poppet. The motion of the diaphragm, rod and poppet assembly closes the reverse acting port to the return line and opens the direct acting port, making the thermostat direct acting. Lowering the air supply back to 18 psi (124 kPa) will reverse the changeover procedure and the thermostat will again be reverse acting.

**Operation,
 continued**

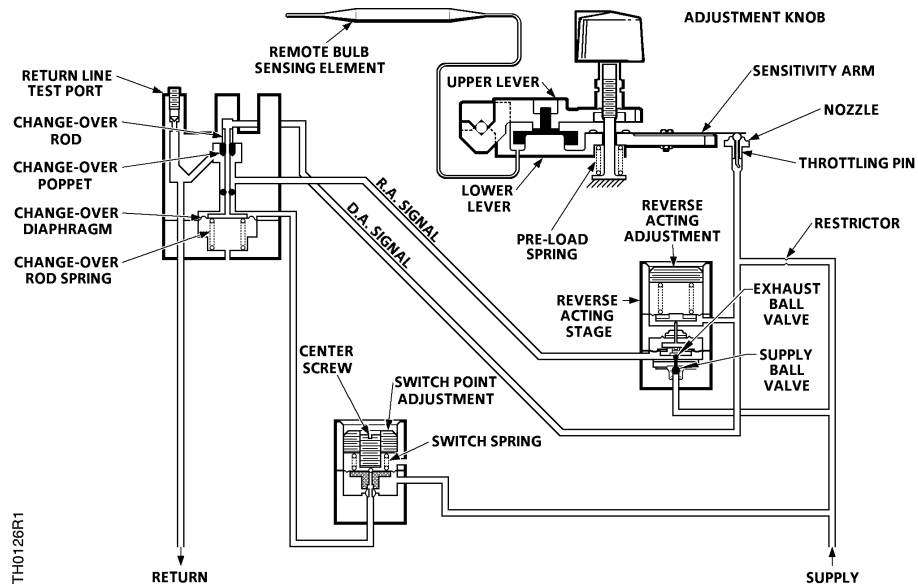

Figure 1. Thermostat Operation.

Calibration

The thermostats are factory calibrated at 72° F (22° C) and 7-1/2 psi (52 kPa) control pressure.

General

1. Determine the temperature at the remote bulb.
2. Set pointer to the temperature found. Dial increments are approximately five degrees on the major divisions with one degree subdivisions, beginning at 60° F clockwise to 85° F.
3. Loosen (do not remove) the return line test port screw. Slip the rubber line over test port and connect to test gauge (*Figure 2*).

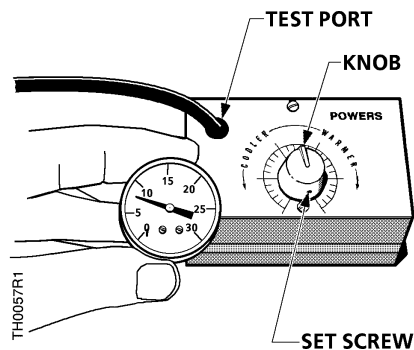

Figure 2. Test Port and Gauge used for Calibration.

4. With the knob set at the temperature of the remote bulb, the output (return line) pressure should be between 7 and 8 psi (48 and 55 kPa) for all models. If the output pressure is not 7 to 8 psi (48 and 55 kPa), remove knob after loosening its set screw. Then rotate the set point adjustment post until pressure is 7 to 8 psi.
5. Replace knob and set pointer to temperature of the bulb, lock, and then turn to desired setting.

The thermostat is now in calibration.

Calibration, continued Single Action

The direct acting or reverse acting thermostat may be calibrated at any pressure. It is suggested that 7-1/2 psi (52 kPa) be used.

Dual Action

On the HC thermostat, calibration should be at 7-1/2 psi (52 kPa) for both DA and RA. This is due to the use of one thermal system and a reversing relay to give the action desired. If calibrated at 7-1/2 psi (52 kPa) for winter, the summer calibration will be 7-1/2 psi (52 kPa). If 9 psi (62.1 kPa) is used for winter, 6 psi (41.4 kPa) will be summer's calibrated pressure. *Figure 3* shows the relationship of the DA and RA calibration points. If the same pressure is desired for both seasons, the RA section of the thermostat needs to be recalibrated (follow the RA calibration procedures).

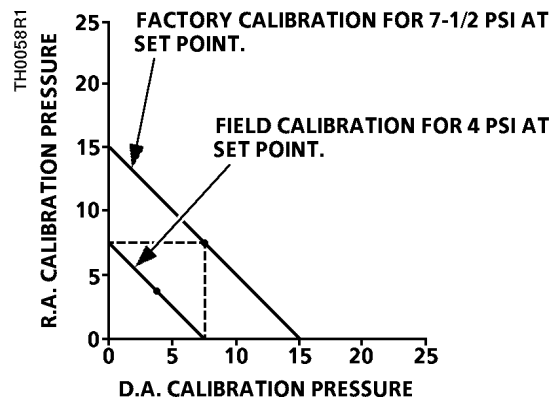

Figure 3. Dual Action Calibration Points.

Reverse Acting Stage

See *Table 1* for pressures and changeover pressures.

The reverse acting stage is factory adjusted and does not require field adjustment. If the adjustment is disturbed, re-adjust as follows:

1. With the main air supplies set for 25 psi (172 kPa), connect a PRV with gauge to the supply side of thermostat and set at 25 psi (172 kPa).
2. Remove knob and cover from thermostat, as shown in *Figure 4*.
3. Open bleed screw on test port and connect gauge.
4. Rotate adjustment post to give an output within 1/2 psi (3.4 kPa) of calibration pressure.
5. Adjust PRV for 18 psi (124 kPa) air supply; observe the control pressure. If it is not within 1/2 psi (3.4 kPa) of calibration pressure, adjust the reverse acting adjustment until it is. Apply thread locker to the screw setting.
6. Remove test port gauge; close bleed screw.
7. Replace cover and knob.
8. Lock knob in place with pointer at bulb temperature.
9. Set knob at desired temperature setting.

Calibration, continued

Heat-Cool Thermostat Changeover

See *Table 1* for air pressures and changeover pressures.

The changeover is a factory adjustment; it is sealed with thread locker and does not require field adjustment. If for some reason this adjustment is disturbed, re-adjust as follows: (See *Figure 4*)

1. Supply the thermostat with an air supply equal to the appropriate changeover pressure.
2. With the exhaust adjustment (center screw) backed out several turns, turn the switch spring adjustment (outer screw) down snug, and then back off, until air can be heard bleeding out.
3. Turn the exhaust adjustment down snug and back off approximately 1/8 turn.
4. Seal both screws with thread locker to prevent further movement.

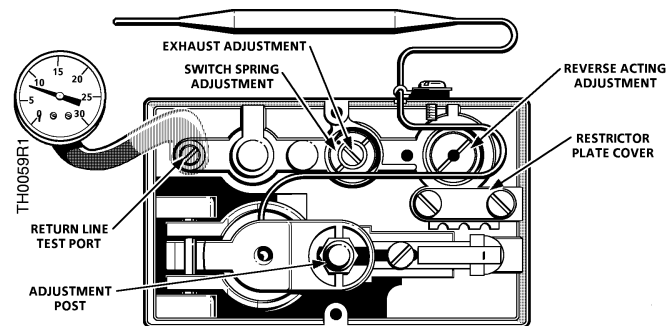

Figure 4. Heating/Cooling Changeover.

Installation

- A mounting bracket (188-077) is included for mounting the thermostat within the various units.
- *Figure 5* shows a typical installation where the mounting bracket is fastened to the partition with two sheet metal screws (034-257).
- Mount the remote sensing bulb in the air stream of the return air (near the inlet of the fan).
- Avoid metal-to-metal contact between the bulb and unit to prevent the soft copper sensing bulb wearing through due to the rubbing action caused by the unit vibrating.
- Use the adhesive backed cable clip (141-311) supplied with the thermostat to fasten the capillary and/or bulb in the return air stream.
- If there is not enough room to mount the thermostat in a convenient location, or if the set point dial must be in the same compartment as the fan switch, order an extension shaft kit (188-101). The thermostat may be mounted in any convenient location within the eight-inch length of the shaft extension cable shown in *Figure 6*.

**Installation,
 contintued**

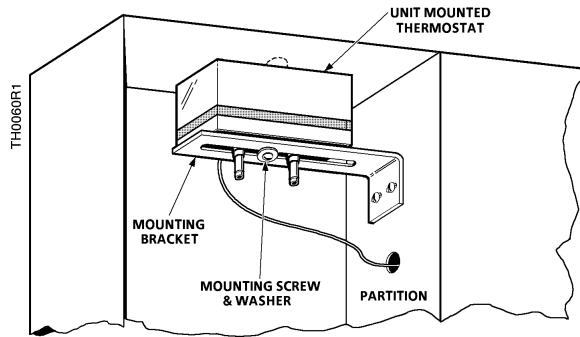

Figure 5. Unit Mounted.

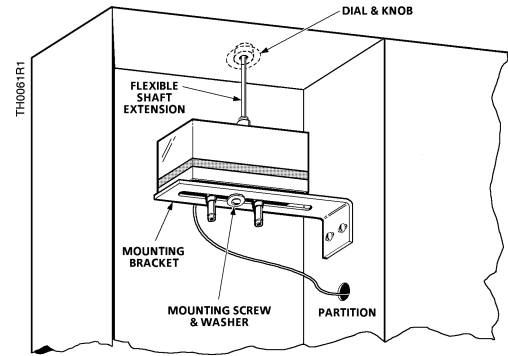

Figure 6. Mounting with Extension Shaft.

**Preventive
 Maintenance**

The construction of the TH 188 Thermostat makes it virtually maintenance-free. But like any pneumatic thermostat, it should be checked for calibration at least once each year (usually just before the heating season).

Table 3. Troubleshooting.

Complaint	Check		Possible Cause	Corrective Action
Return line pressure 0 psi (0 kPa)	Supply Air		No Air	As Required
	*Heating 25 psi (172 kPa)	Calibration	Out of calibration	Recalibrate
		Restrictor	Clogged or dirty	Clean or replace
		Sensing element	Loss of charge	Replace sensing element
		Direct acting stage	Internal binding or leaking	Replace thermostat
	*Cooling 18 psi (124 kPa)	Calibration	Out of calibration	Recalibrate
		Throttling pin	Dirt built up around pin	Clean or replace nozzle ass'y
Reverse acting stage		Internal binding or leaking	Replace thermostat	
Return line pressure 18 psi (124 kPa) or greater	Supply Air		Pressure Too High	As Required
	*Heating 25 psi (172 kPa)	Calibration	Out of calibration	Recalibrate
		Throttling pin	Dirt built up around pin	Clean or replace
		Direct acting stage	Internal binding	Replace thermostat
	*Cooling 18 psi (124 kPa)	Calibration	Out of calibration	Recalibrate
		Restrictor	Clogged or dirty	Clean or replace
		Sensing element	Loss of charge	Replace sensing element
		Reverse acting stage	Improperly adjusted	Re-adjust
		Reverse acting stage	Internal leaks or binding	Replace thermostat
	Excessive cycling	Lever assembly		Sticking/binding of levers

*See Table 1 for Honeywell and Johnson Controls pressures.

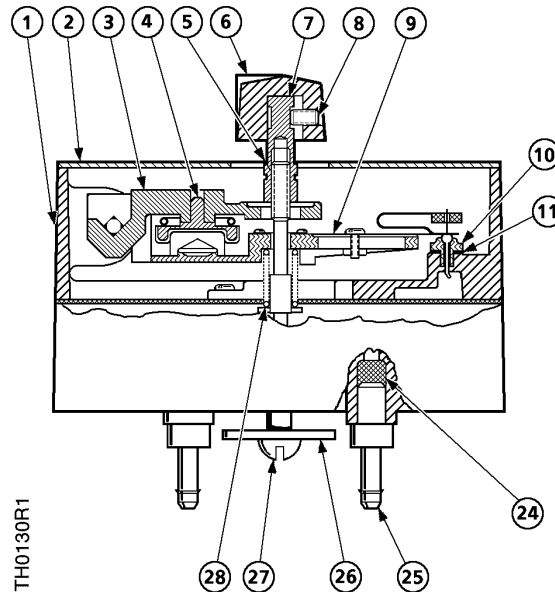

Figure 7. See Tables 4 and 5.

Table 4. Parts List (See Figures 7 and 8).

Item	Part Number	Description	Number Req'd	Material
1	--	Housing assembly	1	Zinc alloy
2	--	Cover plate	1	Aluminum
3	--	Upper lever	1	Aluminum
4	188-057	Sensing element	1	Copper
5	--	Adjustment post (HC & RA)	1	Steel
6	188-122	Knob	1	Zinc alloy
7	--	Adjustment knob (DA only)	1	Brass
8	034-370	8-32x1/4 sock. hd. set screw	1	--
9	--	Lower lever assembly	1	--
10	188-082	Nozzle assembly	1	--
11	188-080	Gasket	1	--
12	833-009	Seal Screw	1	Brass
13	--	Switch spring adjusting nut (HC only)	1	Brass
14	--	Exhaust adjusting screw	1	Brass
15	030-312K	6-32x5/16 pan hd. screw	1	Steel
15a	--	Capillary clamp	1	Plastic
16	--	RA adjustment nut (HC & RA)	1	Brass
17	034-014K	Restriction plate screw (HC & RA)	1	Brass

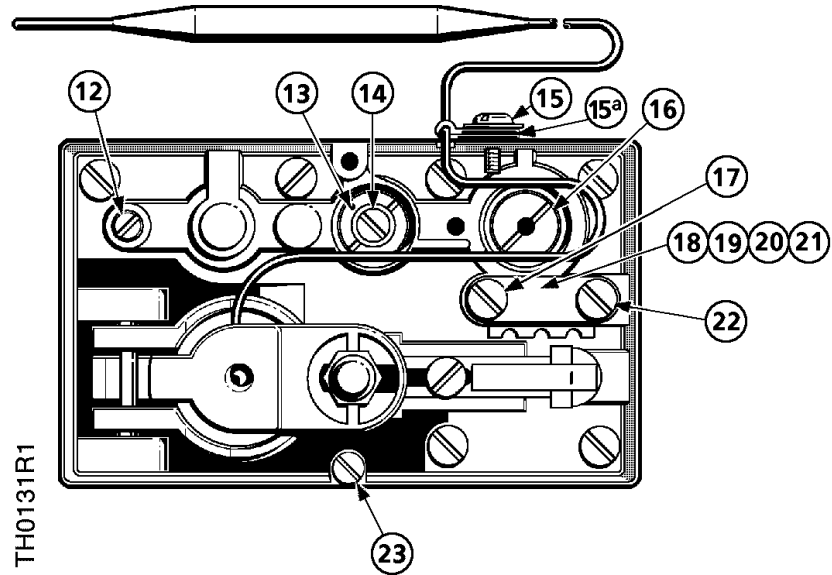

Figure 8. See Tables 4 and 5.

Table 5. Parts List (See Figures 7 and 8).

Item	Part Number	Description	Number Req'd	Material
18	--	Restriction cover	1	Steel
19	*	Restrictor (2 Tabs 20 scim)	1	Brass
	*	(4 Tabs 40 scim)		Brass
20	*	Restrictor gasket, upper	1	Rubber
21	*	Restrictor gasket, lower	1	Rubber
22	--	Restrictor plate screw (long) (HC & RA)	1	Steel
	--	Restrictor plate screw (long) (DA only)	1	Steel
23	--	Cover screw	2	Steel
24	--	Filter	1	Felt
25	--	Polytube adapter	2	Brass
26	--	Mounting washer (HC & RA)	1	Steel
27	--	Mounting screw (HC & RA)	1	Steel
	--	Mounting nut (DA only)	1	Brass
28	--	Pre-load spring	1	Spring Wire

*These parts are in Restrictor Replacement Kit (188-159) shown under *Accessories*.

Dimensions

Dimensions in
 Inches (Millimeters)

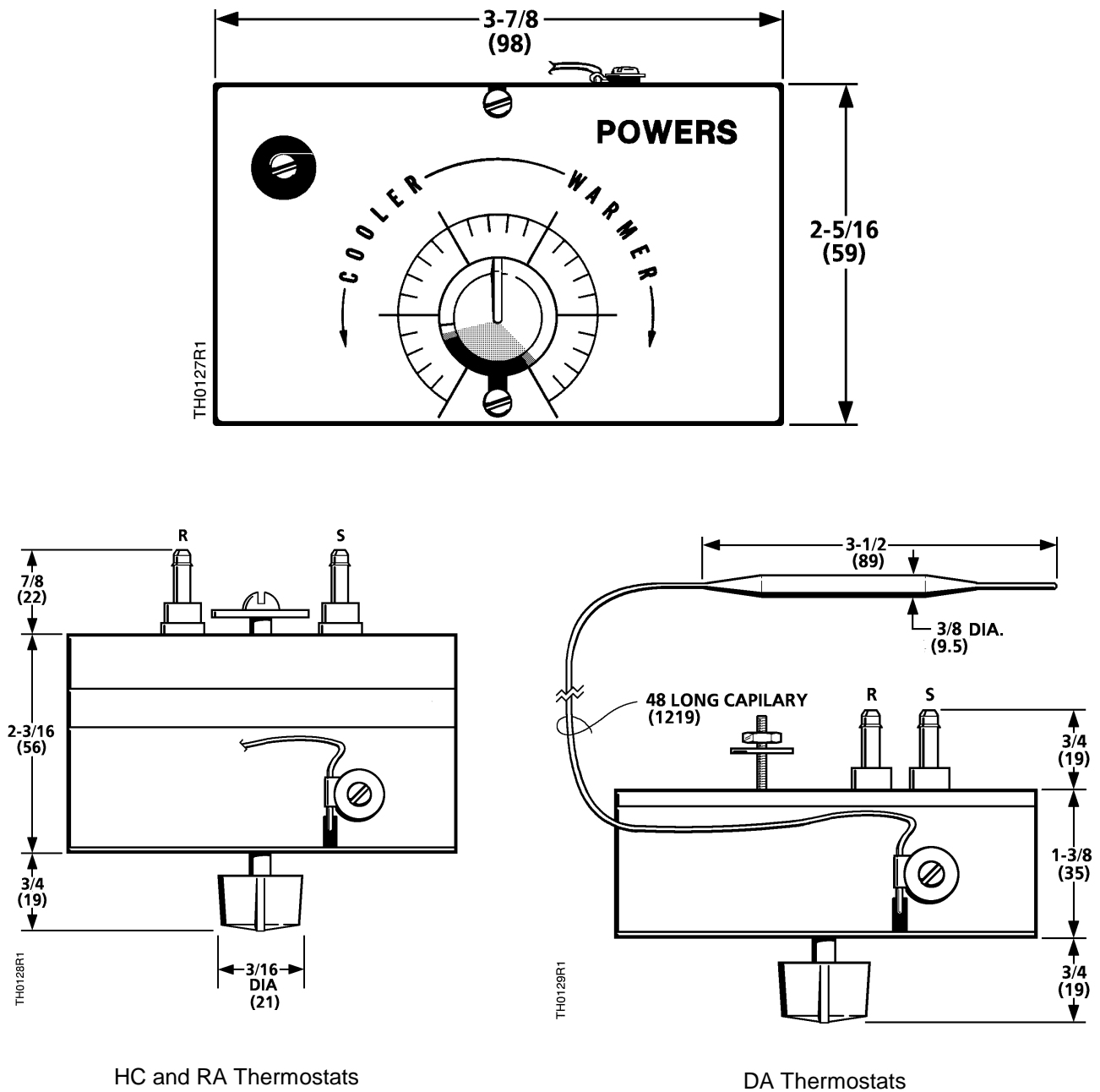

Figure 9. Dimensions.

Information in this publication is based on current specifications. The company reserves the right to make changes in specifications and models as design improvements are introduced. Powers is a trademark of Siemens Building Technologies, Inc. © 2000 Siemens Building Technologies, Inc.